



This information is brought to you by
Owls Hall Environmental working in
partnership with Klargester products.



Excellent Treatment

0845 375 1801
www.ohel.co.uk

OPERATION OF KLARGESTER SEPTIC TANKS



Introduction

A septic tank is a retention vessel designed to receive sewage, hold it for a period and then release a clarified effluent. Sewage is a mixture of toilet wastes, kitchen wastes and so called grey wastes i.e. liquids which include washing, bath and washing machine wastes.

A septic tank is primarily a liquid/solid separation system, although there may be some limited biological activity within the sludge and the liquid interface.

As the name **septic** implies, the sewage entering the tank becomes septic. If you look this up in a dictionary or thesaurus, you will see the alternative words, - putrid, toxic, noxious, unsanitary, rotten, decaying. It is possible that at sometime, smells will be detected from somewhere in the drainage system. These can be minimised by correct installation location and by controlling the sewage inputs into the septic tank.

Septic Tank Operation

The septic tank is always full. Clarified effluent is displaced from the tank outlet into the irrigation, soak-away/distribution system, by the incoming sewage flow.

Within the tank, there are complex internal baffles which are arranged to assist the solids to separate from the liquid. Some solids float, but most settle. Little by little, sludge builds up within the main chamber of the tank.

Floatables, i.e., oils, grease and some faecal constituents, undergo some microbial decomposition and form a floating layer of white brownish scum. In some tank designs this is exposed to the air, and after a period, hardens to form a crust.

Settleable solids sink to the bottom of the tank where they may also undergo some bacterial decomposition acquiring a black colour.

Some of the sewage constituents have the same density as the clarified effluent. Other particles or constituents may be denser but tiny gas bubbles attach to them, thus they become lighter and they stay in the clarified effluent forming a *suspension*.

Septic Tank Design

Klargester septic tanks are designed to maximise the separation of solids and liquids, minimise turbulence and provide a zone from where discharge is made at a low flow. The purpose of the design is to produce the best quality of effluent and to extend the life of the soakaway or irrigation system. This is very important considering the huge cost of laying a new distribution system.

Process performance is paramount. A septic tank that does not separate the liquid and solids is not doing its job.

Klargester septic tanks have been tested for their sludge retention performance by the British Board of Agrément (BBA) who independently assess construction products.

Klargester are proud of their reputation as suppliers of "The Tanks That Outperform The Rest."

Klargester have progressively improved their septic tank internal design over the 35 years they have been manufacturing septic tanks. Most of the spherical septic tanks we supply have one of three different internal baffle designs, all of which include a three stage upward flow route.

a) Submerged Ball

The inlet arrangement directs sewage into the main body of the tank, zone 1. This zone is very large allowing both settleable and floating solids to be retained. Some floating solids may rise out of the zone, but most are retained within the zone by the baffle arrangement and the submerged floating ball. The ball seals zone 1 from zone 3.

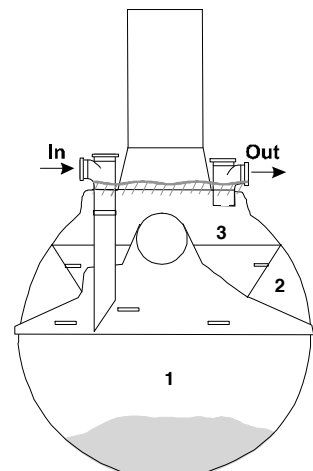

Clarified effluent rises through slots in the baffle, from zone 1 into zone 2. Small particles may rise with the clarified effluent and a further scum layer may accumulate at the top of zone 2.

Another baffle positioned higher within the tank, separates zone 2 from zone 3. This baffle has slots positioned at a different orientation to provide a long flow path.

Clarified effluent is discharged from zone 3 into the outlet pipe connected to the irrigation system.

b) Raised/(Red or cream coloured) Neck

The sewage enters the tank via the inlet pipework and is directed into the base of the primary zone 1 where most of the solids settle. Some floating particles rise and a scum develops at the surface. The raised neck of the upper cone is above the normal liquid level and this ensures that scum is retained.

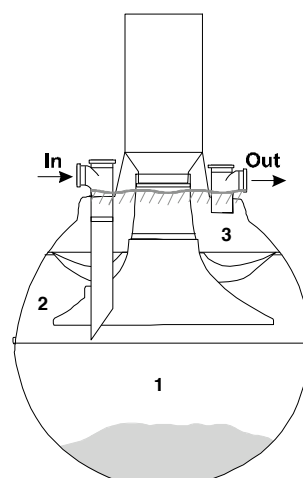

The lower conical baffle arrangement allows liquid to rise at the outside of the tank. Heavy particles sink within the rising liquid. As the liquid ascends, the rate of liquid rise slows, allowing additional time for the smaller and lighter particles to settle.

The baffle design of the second zone allows floating fine particles to be retained against the tank wall, eventually allowing a submerged scum layer to develop. Once formed, smaller fine particles may be collected by this layer, hence a more "mature" unit will work better than one recently installed or just emptied.

There are slots positioned towards the inside of the upper baffle. Liquid rises through these slots into the final zone. The upper baffle is in the form of an inverted cone, the design of which aids consolidation and coagulation of particles. Settleable particles can fall through the same slots and be returned to the primary zone.

c) Plug and Handle

These tanks were provided by Klargester in the 1970's and use a flat plug, held in place with a handle, instead of the submerged ball to retain the floating solids within the main chamber. Their baffle orientation and chamber design is very similar to that described in a) above.

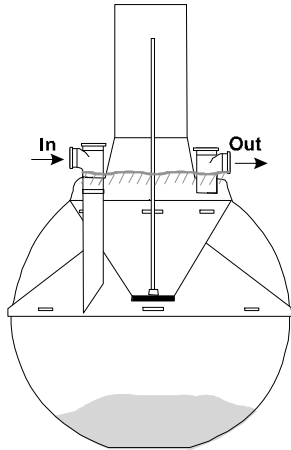

Smells and Odours

Gases can develop when bacteria decompose some of the sewage constituents.

There is usually very limited bacterial activity within the sludge as there is little oxygen available to allow the bacteria to grow.

Any bacterial activity that does occur may obtain its oxygen from bound up chemical compounds such as sulphates (SO_4). Hydrogen sulphide gas may be produced, by anaerobic bacterial activity, its smell is particularly distinctive, often described as a sweet rotting cabbage smell.

Gases travel from the top of the liquid level in the septic tank into the vent or to the house's sewer pipe or soil stack, up to the roof terminal where they are vented to atmosphere.

Sometimes the smells detected derive from the irrigation system, or from other sources within the drainage system.

The chart on page 5 offers guidance to help you identify the origin of a smell and suggests ways of eliminating the cause(s).

Installation of Septic Tank & Associated Pipework

It is very important that you have correct venting and connections relating to your particular tank location and site situation. Klargester provide guidance in their Technical Data Sheet, TDS0004. "Points to consider before siting your Septic Tank." a summary of which follows.

- Building Regulations require the system to be adequately ventilated. A Klargester septic tank needs fitting with an appropriate cover and frame and connection to a correctly designed and installed soil stack system which ensures adequate ventilation. An

additional local air inlet can be fitted to the tank where circumstances and conditions require it. The direction of the prevailing wind in relation to the property(ies) should be considered when selecting the tank site. If an air admittance valve has been installed inside the property, perhaps within the roof cavity, then the septic tank must be independently vented.

- For dimensions of septic tanks and independent venting arrangements see Klargester drawing No. DS0521 ($2.7m^3$ to $4.5m^3$) & DS0008 ($6m^3$ to $9m^3$) or PD0213 (2.8^3 to $4.6m^3$).
- A fall of about 1 in 40 is recommended for the drain from the house to the tank. (Although newer plastic products may allow a fall of up to 1 in 80).
- A fall of about 1 in 200 is required for the land irrigation drain. These drains should end a minimum of 10m distance from any water course.
- A suitable cover and frame must be fitted relative to the neck size. Klargester covers and frames allow venting when connected to a soil stack system. Any other suitable covers and frames may be used.
- Covers & frames, any other access or inspection points, may need sealing with a mixture of grease and sand to prevent gases escaping at ground level.

Your plumber or installer should be consulted to check the drains to ensure that the installation and pipework conform to building regulations, and septic tank installation guidelines. The pipe layout must not allow the water to be drawn from water traps or U bends which normally prevent gases rising into the house.

It is good practice to install inspection chambers before and after the septic tank so as to enable inspection of the effluent quality being passed into the irrigation system.

Soakaways/Subsurface Drainage & Irrigation Systems

Klargester provides information concerning their design and installation in Technical Data Sheet TDS0005. This follows the guidelines provided in the British Standard, BS 6297.

The function of drainage systems is to receive the clarified sewage from the septic tank and discharge it underground in the soil. The soil environment purifies the liquid further providing a separate biological stage for additional breakdown. The purified liquid moves away by percolation, evaporation, plant uptake and transpiration.

The type of soil and its ability to drain, is of paramount importance when deciding if an irrigation system is acceptable.

It is very important to ensure that the drainage system has been correctly designed and installed. If the effluent is not absorbed by the soil, ponding occurs, allowing untreated effluent to surface. If the effluent passes through the ground too quickly, (without treatment by a subsurface biological mat) then untreated effluent can enter a water supply, and cause other problems if the water is later abstracted for potable use.

Corrugated pipework, because of its intrinsic design is generally not advised (even by the manufacturers) for use in a septic tank irrigation system as:-

- It is difficult to lay evenly, allowing low points where effluent can collect. This can cause over saturation of a local area.
- The corrugations can retain sediments which may over time, cause blockages.

Problems experienced with the irrigation/soakaway system should be referred to your original installer or local drainage contractor.

Incorrectly designed, or old soakaway systems exhibit their problems. Systems that are too short may allow untreated liquid to surface. If the soil is insufficiently porous, the liquid will stagnate and pond to the surface. As soakaway systems age, the biomat may thicken and as a result progressive blockages can occur. Blocked areas may relate to how level the system is laid and the flow pattern through the pipes.

Systems that have been installed where the water table is too high, or where the water table moves upwards, during wet or winter periods exhibit problems. The soakaway system may allow the ground water to drain back into the tank, and sewage may back up in the incoming drains as effluent cannot flow out of the tank.

You should establish the cause of the problem in your particular circumstance and if necessary consider renewing the soakaway system. Occasionally the use of pumps after a septic tank may assist. The use of a BioDisc® should be considered. BioDiscs are package treatment plants which contain an aerobic biological culture and produce a fully treated effluent with low amounts of BOD and suspended solids. (Generally <20 mg/l BOD and <30 mg/l SS). The low levels of pollutants discharged within the fully treated effluent means that a BioDisc can be used where a soakaway cannot be renewed or in place of a septic tank feeding an inadequate soakaway. With EA consent, a BioDisc effluent may be discharged into open watercourses or ditches. Please contact us.

Smells in the irrigation system may be caused by:-

- Ponding, caused when effluent surfaces out of the top of the ground. As the effluent "decays" smells are produced.
- A chemical within the effluent that damages or kills the biological treatment mat within the soil, which then rots and decays.
- Excess bacterial activity, caused by increased nutrient release possibly as a result of a need to desludge the tank.

Good Housekeeping & Liquid Disposal Practises

You should review the wastes that enter into the system.

- Avoid using waste disposal units to chop up and dispose of vegetable peelings and wastes such as coffee grounds. As you know these take a very long time to compost and take even longer to decompose in water. Vegetable materials are unlikely to degrade within a septic tank. They add to the bulk and increase the emptying frequency.
- Avoid excess use of chemicals such as bleaches, Milton nappy disinfectant and other strong cleaning chemicals. If the products' purpose is to kill bacteria in your house, they may also affect bacteria in your tank.

- Do not use your system to dispose of any chemicals, e.g. medicines, paint brush cleaners, white spirit, turpentine, creosote, paint products, photographic chemicals, motor oil, anti-freeze, brake fluid, weed-killers, insecticides, fungicides and other gardening chemicals, etc.
- Do not use caustic or proprietary drain cleaners. These all adversely affect the system and can cause noxious smells. Eventually they will be released from the tank into the soakaway causing damage to the bacteria in the soil. These chemicals may also damage the submerged ball within some tank designs, allowing the release of solids and smells.
- Do not allow excessive amounts of grease, cooking oils and fats to enter the system. These do not readily degrade, and partial degradation may produce nasty smells.
- Do not allow nappies, sanitary towels, rags, soft toys, etc. into the drainage system. Disposable nappies and sanitary towels (which do not cause problems in municipal systems) do not degrade in the septic tank and add to the sludge volume. They cause problems if they block the drains.
- Do not allow excess water to enter the system. In periods of heavy rainfall, the volume of water shed from a roof or sealed surface can totally overwhelm the capacity of the tank and flush out solids and unclarified effluent. Disconnect all surface water sources.

Bacterial Additives

These may sometimes be of benefit and may reduce *some* smell conditions, however before using them, we do suggest that you review your installation and the wastes that enter. Ensure that any manhole covers or tank covers are sealed and that ventilation arrangements are correct.

The compounds contain facultative bacteria which re-inoculate your tank helping to biodegrade and break down the accumulated sludge. But, if your system also receives lots of chemicals, adding bacteria may not provide any benefit.

The use of bacterial additives, in addition to reducing smells, may also decrease the volume of sludge which becomes consolidated. However, as a result of the increased bacterial activity, more and different gases may be released. There are cost savings to be made should you be able to desludge your system less frequently.

Should you wish to use a bacterial additive, please contact us for their supply.

Routine Maintenance

Very little activity is required on your part especially if you avoid disposing the items which cause blockages, such as rags, cloths and grease. We suggest a routine inspection of your manholes and inspection chambers to ensure that there are no blockages and that the effluents are running freely.

Desludging

Klargester recommends emptying the septic tank at least once a year. This assumes that you have the correct size of tank installed in relation to your water use and household size. The table below provides guidance as to the most appropriate tank selection for your domestic

household, but for advice on other situations such as office developments please contact us.

Septic Tank Volume (litres)	Number of people in the household assuming each person uses a volume of	
	180/ person/day (NORMAL)	250/ person/day (HIGH)
2720/2800	4	3
3750/3800	9	7
4500/4600	14	10
6000	22	16
7500	30	22
9000	39	28

The decision on how frequently to empty the tank is yours to take, considering your addition of solids, bacterial compound and household size. Where you have extended the emptying frequency, you should regularly check the condition of the effluent passed to the soakaway in the inspection chamber for the absence of visible solids.

Do not over extend the desludge period as this may allow sludge to accumulate to such an extent that damage can result within the septic tank. It may be difficult for the waste disposal contractors to empty tanks with very high solid contents. Always check the appearance of the septic tank effluent and never allow the septic tank to become blocked.

If the sludge is allowed to accumulate in the tank for too long, there will be a smell. More importantly, excess sludge in the tank allows excess release of solids into the soakaway drains which may become blocked. Once the soil around the drains has blocked, it is very expensive to repair or replace. We do not recommend extending the desludge frequency at the expense of your irrigation system.

You may know of neighbours who say that they have never emptied their septic tank. This may be because they have an old tank which was built of brick, or perhaps a pit with a very large capacity. As these systems age, they tend to leak both liquids and solids through the old cement joints rather than through the designated irrigation drains. The result is often contaminated areas and ponding local to the tank.



α Alpha Tank

Desludging Instructions

Always employ a licensed waste disposal contractor who holds the relevant permits to carry and dispose of wastes. You should be provided with a disposal note.

We suggest the use of a maximum suction hose diameter of 4" or 110 mm.

a) Spherical septic tanks with submerged floating balls

Lower the tank hose down through the access shaft close to the wall of the neck and draw off sufficient effluent to cause the ball to drop away from its seating giving access to the main sludge holding chamber.

Remove sludge from the main chamber. Care should be taken to avoid unnecessary striking of the ball seating by the suction hose. When the tank refills, the ball will automatically re-locate in its seating to seal off the main sludge holding chamber.

b) Spherical septic tanks with raised necks

Lower the tank hose down through the centre access shaft and remove the sludge from the main chamber. Care should be taken to avoid unnecessary striking of centre baffles by the suction hose.

c) Spherical septic tanks with plug and handle

Lift out the plug using the handle. Lower the tank hose down through the centre access shaft and remove the sludge from the main chamber. Care should be taken to avoid unnecessary striking of centre baffles by the suction hose. Replace the handle and allow the tank to refill.

Non Domestic Sewage

Sewage from a commercial source, i.e. catering establishments, pubs and restaurants usually requires the installation of a suitably sized separate grease trap which is installed on a separate drain from toilet and other wastes. Other issues should also be considered, please contact us for guidance.

Large Cylindrical Septic Tanks

These tanks are generally supplied for multiple housing systems or for commercial applications. Please contact us should you have any queries about their operation or application.



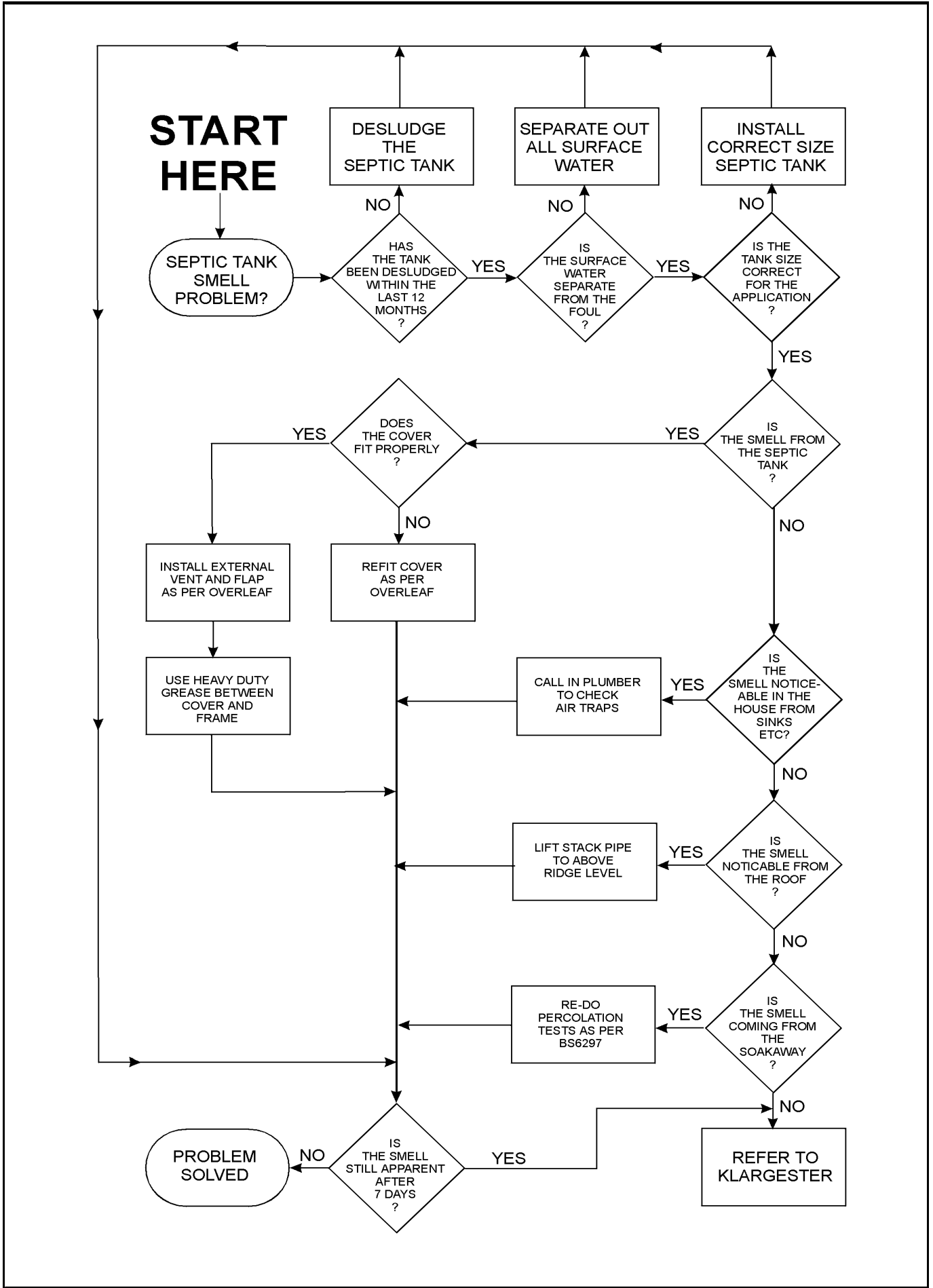

Fitting Cover & Frame

Ensure the inlet pipe and the tank access shaft are set at the correct height.

Trial fit moulded frame onto shaft ensuring that there is no interference with the surrounding earth.

Lift off the frame and place concrete around the vent and neck.

Set the moulded frame into position allowing the concrete to fill the underside of the moulding.

Fix the moulding to the shaft as shown.

Fit access cover into frame.

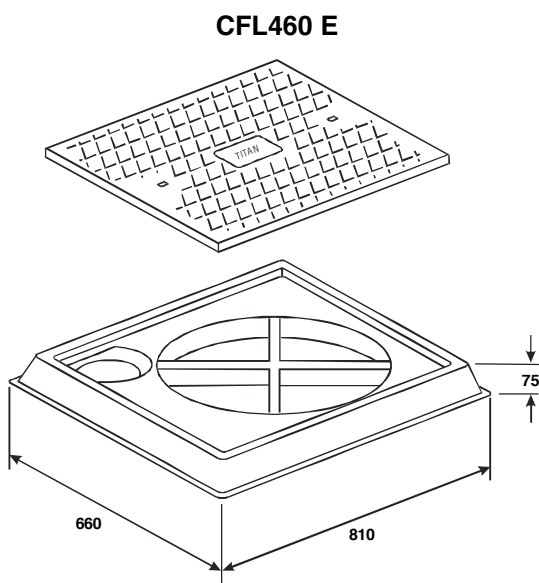

Venting

Additional pipework is necessary to install a local vent which may be required in addition to your roof soil stack. Please contact your installer.

Please note the supply of the additional pipework is the responsibility of customer installing.

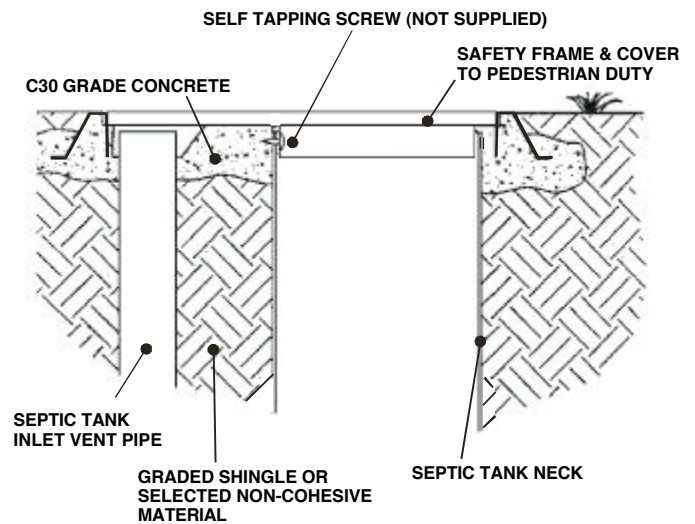

Klargester Environmental
College Road North, Aston Clinton, Aylesbury, Bucks, HP22 5EW
Tel: +44 (0) 1296 633033 Fax: +44 (0) 1296 633001
www.klargester.co.uk e-mail: uksales@klargestere.co.uk

Manufacturing and distribution units also at:
Klargester Scotland: +44 (0) 1355 248484
Klargester Ireland: NI +44 (0) 28 302 66799 ROI +353 (0) 48 302 66799



In keeping with the Company policy of continuing research and development in order to offer our clients the most advanced products, Klargester reserve the right to alter specifications and dimensions without notice.